

## NEW ELECTRO-HYDRAULIC CONTROL for P120

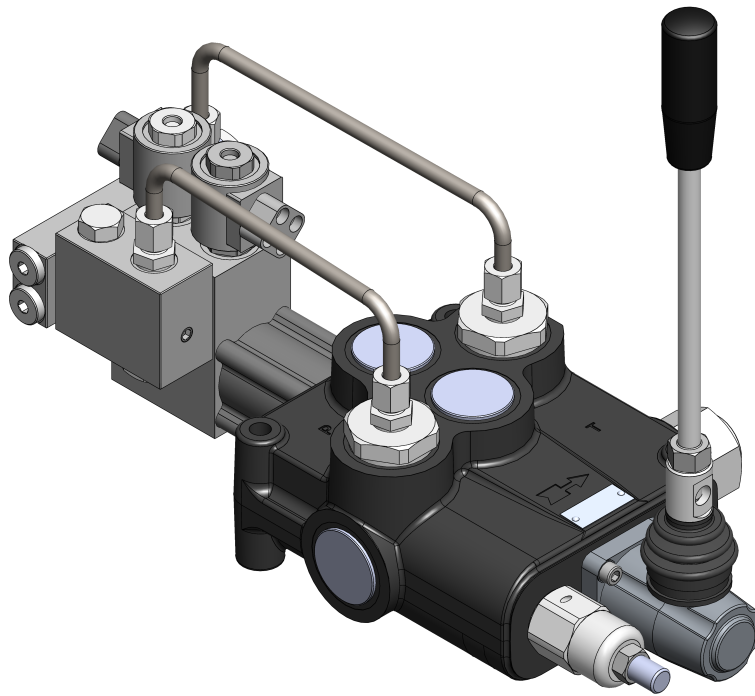

Technical specification		
Flow rate	l/min [gpm]	120 [32]
Max. pressure on A&B	bar [psi]	300 [4350]
Leakage (A,B to T) at 100 bar [1450 psi] and 46 cSt	cm <sup>3</sup> /min [in <sup>3</sup> /min]	6 [0.37]
Operating pressure	bar [psi]	10 to 50 [145 to 725]
Max. pressure in L	bar [psi]	25 [363]
Solenoid operating features		
Nominal voltage tolerance	%	±10
Power rating	W	24
Duty cycle	%	100

Sample order code:  
P120/A1EH3/G/KZ1/CED1/24VDC\*

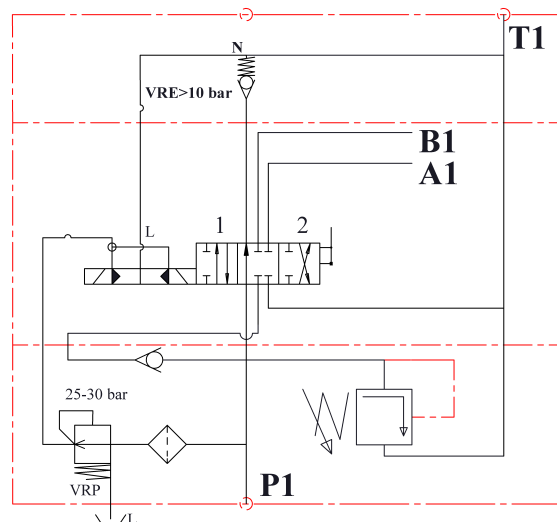

\* The order code is the same as for P40 and P80 with the difference that directional control valve P120 is up to 4 spools