

# KS180

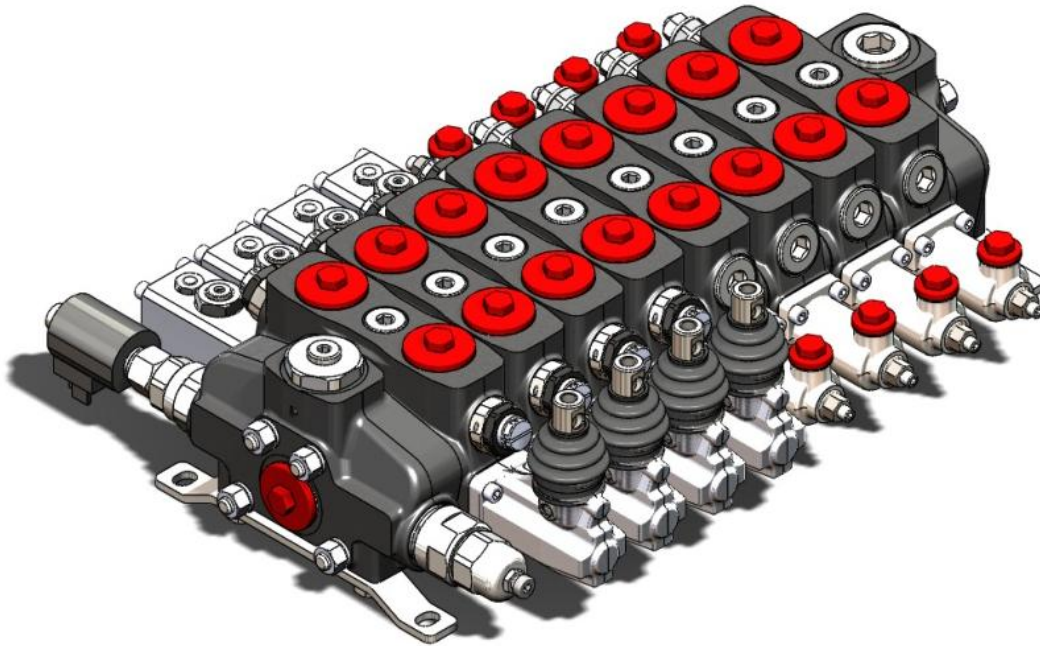

- Fitted with a main pressure relief valve and a load check valve on every working section.
- Available with parallel circuit.
- Optional carry-over
- Variety of port valves (auxiliary valves)
- Available manual, pneumatic, and hydraulic spool control kits.

**NEW PRODUCT**

---

NEW PRODUCT

**KS180**

**WORKING CONDITONS**

This catalogue shows technical specifications and diagrams measured with mineral oil of 32 mm<sup>2</sup>/s – 32 cSt at 40 °C – 104 °F temperature.

Nominal flow rating		160 l/min	42 US gpm
Operating pressure (max.)		315 bar	4600 psi
Back pressure (max.)	outlet port T	25 bar	360 psi
Internal leakage (max.) A(B)→T	Δp = 100 bar (1450 psi) fluid and valve at 40 °C (104 °F)	15 cm <sup>3</sup> /min	0.91 in <sup>3</sup> /min
Fluid		Mineral based oil	
Fluid temperature	with NBR	from -20 °C to 80 °C	from -4 °F to 176 °F
	with FPM	from -20 °C to 100 °C	from -4 °F to 212 °F
Viscosity	operating range	from 15 to 75 mm <sup>2</sup> /s	from 15 to 75 cSt
	min.	12 mm <sup>2</sup> /s	12 cSt
	max.	400 mm <sup>2</sup> /s	400 cSt
Max contamination level		-/19/16 - ISO 4406	NAS 1683 - class 10
Ambient temperature for working conditions	with mechanical devices	from -40 °C to 60 °C	from -40 °F to 140 °F
	with pneumatic and hydraulic devices	from -30 °C to 60 °C	from -22 °F to 140 °F
	with electric devices	from -20 °C to 50 °C	from -4 °F to 122 °F

Note – for different conditions please contact Sales department

**STANDARD THREADS**

**Reference standard**

		<b>BSP</b>	<b>UN-UNF</b>	<b>NPTF</b>
THREAD ACCORDING TO		ISO 228/1	ISO 263	ANSI B1.20.3
		BS 2779	ANSI B1.1 unified	
CAVITY DIMENSION ACCORDING TO	ISO	1179	11926-1	
	SAE		J1926-1	J476a
	DIN	3852-2		

**Ports**

	<b>BSP</b>		<b>UN-UNF</b>
Order code	G34	G1	SAE
Inlet P	G 3/4	G 1	1 5/16-12 (SAE16)
Ports A and B	G 3/4		1 1/16-12 (SAE12)
Outlet T and carry-over C	G 1		1 5/16-12 (SAE16)
Hydraulic pilots	G 1/4		9/16-18 (SAE6)
Pneumatic pilots	NPTF 1/8-27		

# PERFORMANCE DATA

## General

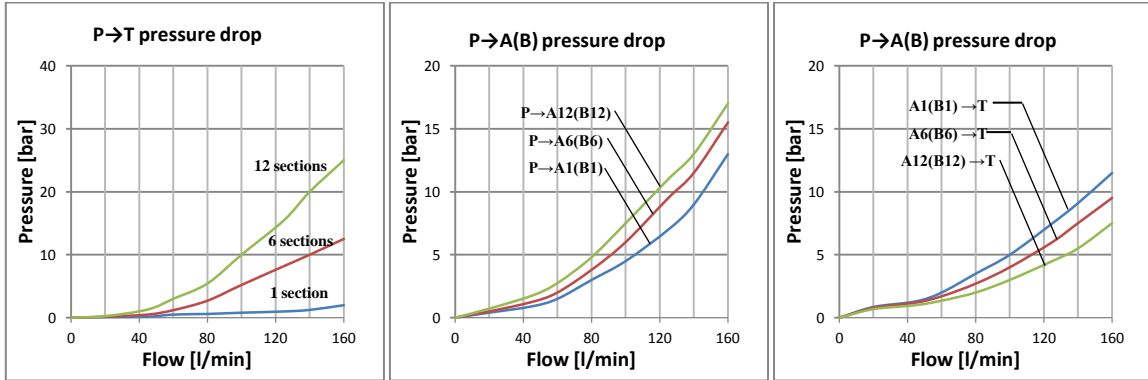

## Main pressure relief valve

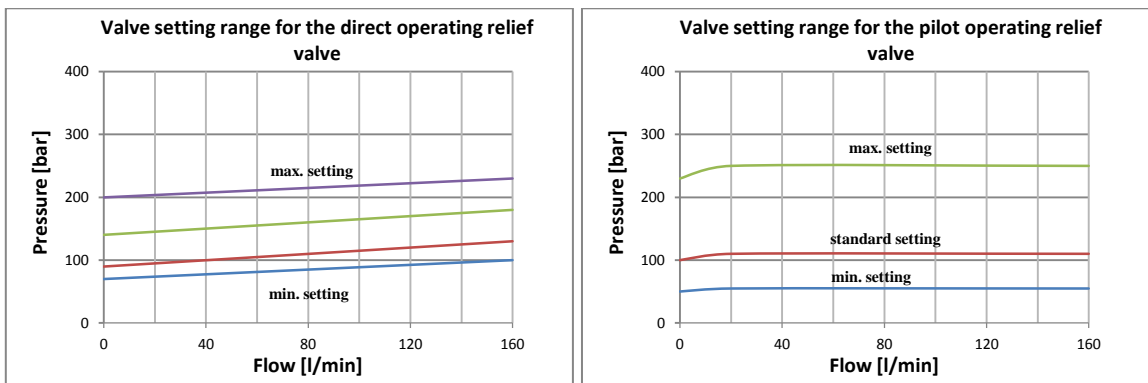

## Auxiliary valves

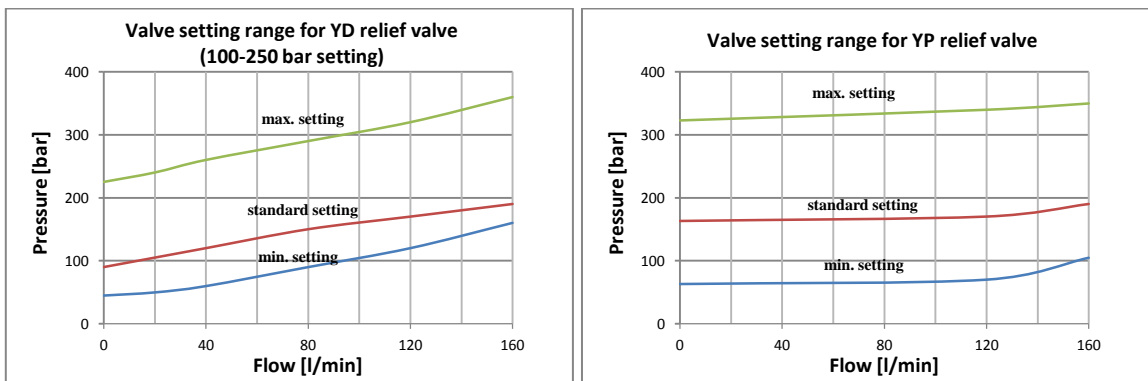

NEW PRODUCT

**KS180**

**DIMENSIONAL DATA**

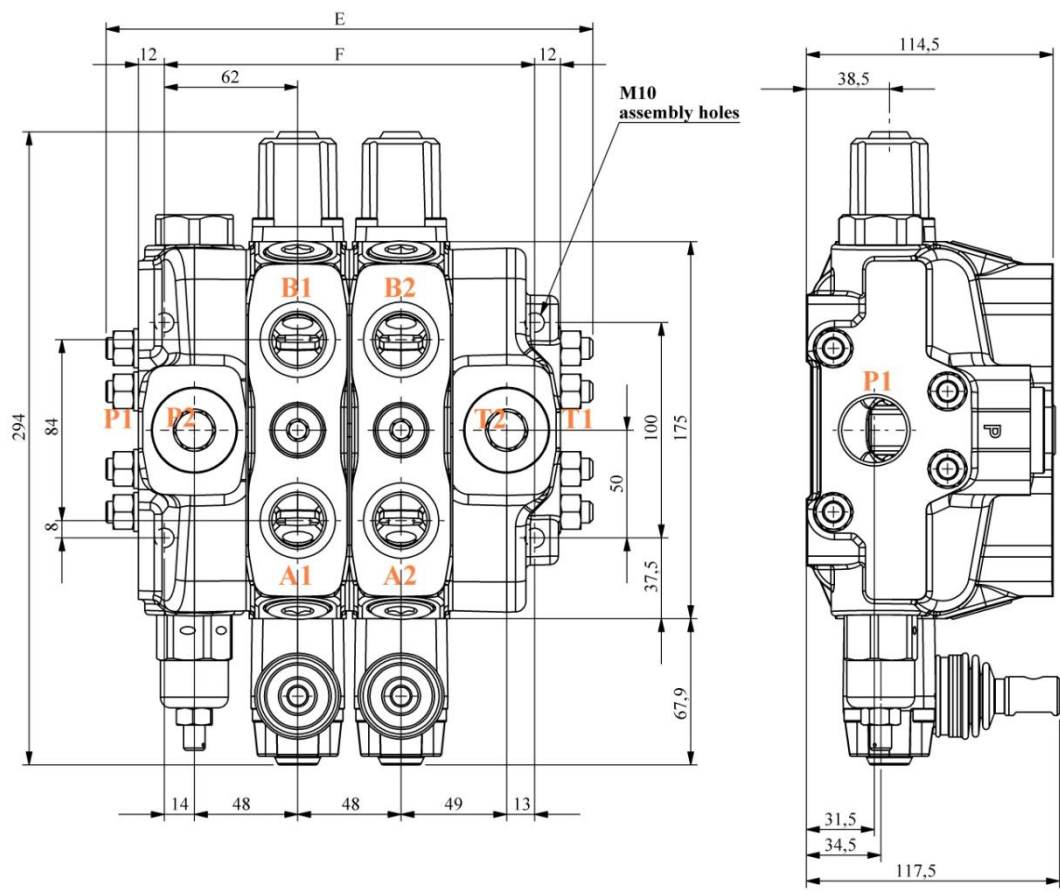

Type	E		F	
	mm	in	mm	in
KS180	176	6,93	124	4,88
2KS180	224	8,82	172	6,77
3KS180	272	10,71	220	8,66
4KS180	320	12,60	268	10,55
5KS180	368	14,49	316	12,44
6KS180	416	16,38	364	14,33

Type	E		F	
	mm	in	mm	in
7KS180	464	18,27	412	16,22
8KS180	512	20,16	460	18,11
9KS180	560	22,05	508	20,00
10KS180	608	23,94	556	21,89
11KS180	656	25,83	604	23,78
12KS180	704	27,72	652	25,67



# HYDRAULIC CIRCUIT

## Open center configuration

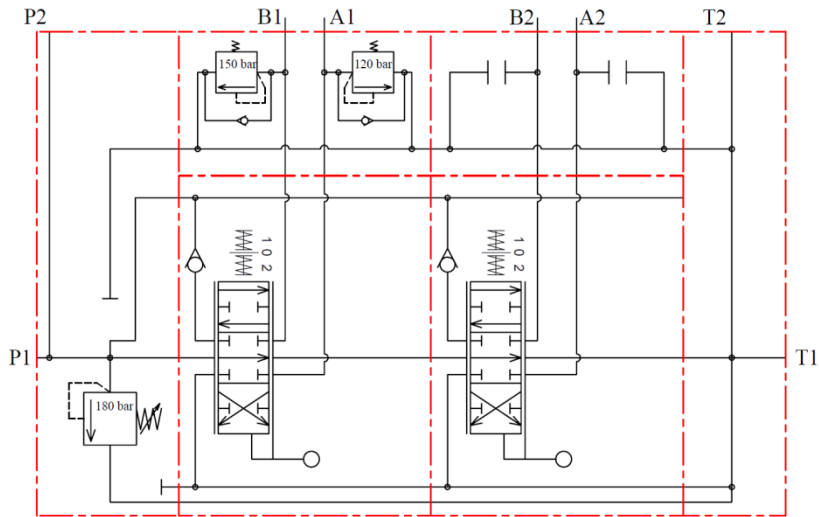

## Carry-over configuration

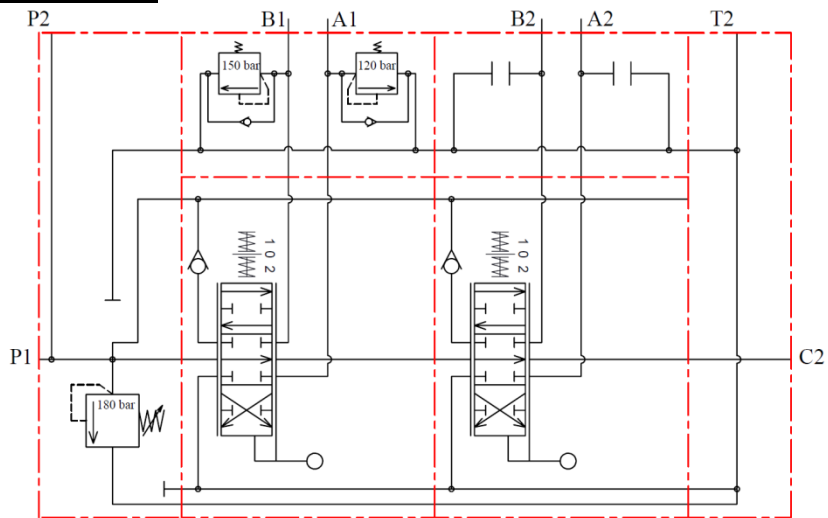

## Closed center configuration

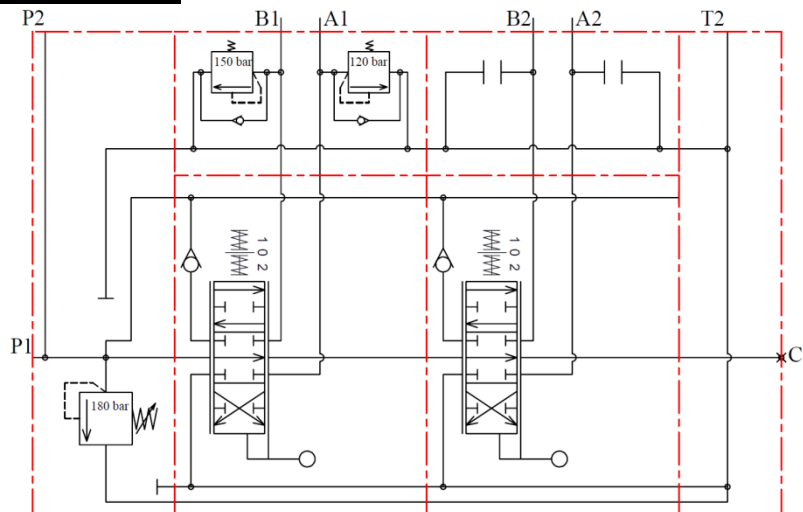

**KS180**

**DESCRIPTION COMPOSITION**

1 2 3 4 5 6 8 9 7 10 11  
 2/KS180/L1(D-120)-/PA1(AoByD-100)KZ1/PA1H(AoBo)/T1/G1

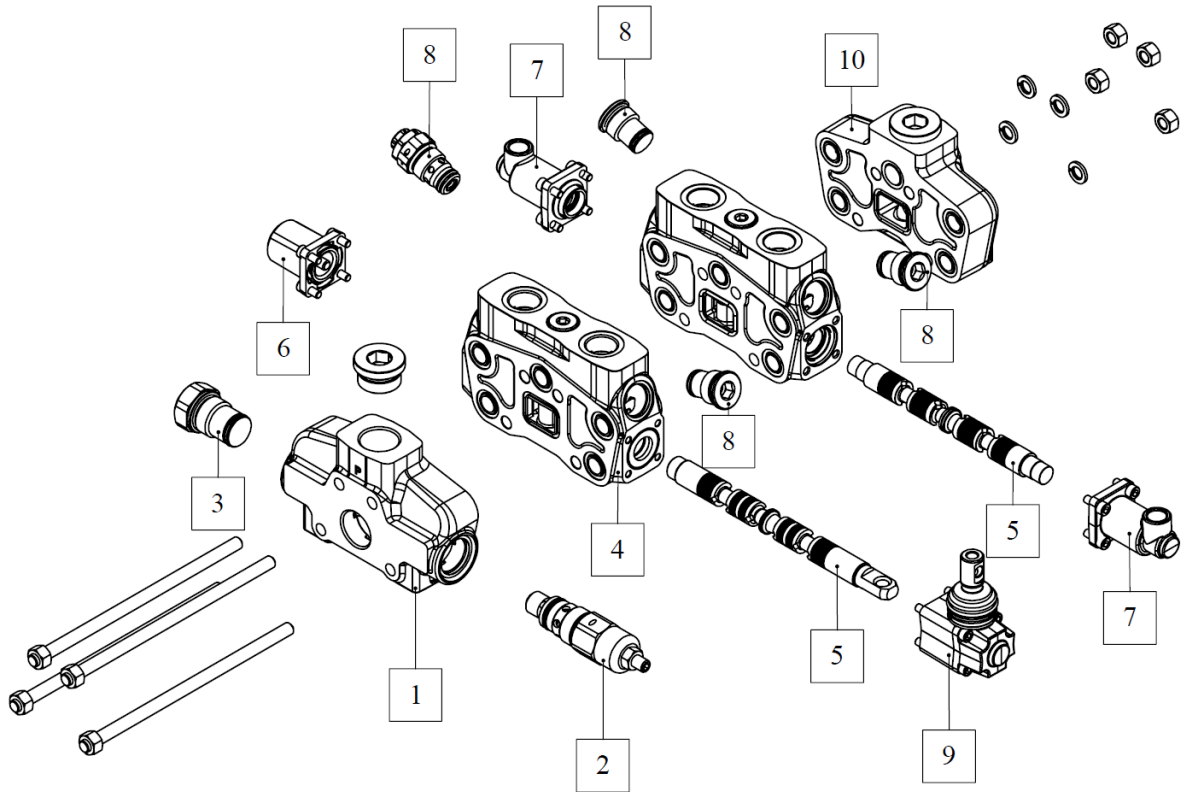

**1 Inlet section**

- L1: Inlet section with side port
- L2: Inlet section with upper port
- R1: Right inlet section with side port
- R2: Right inlet section with side port

**2 Pressure relief valve**

(svp): Relief valve blanking plug

**Direct type D:**

- (D-80): Setting range from 63 to 125 bar (900 to 1800 psi), standard setting 80 bar (1160 psi).
- (D-120): Setting range from 100 to 200 bar (1450 to 2900 psi), standard setting 175 bar (2500 psi).
- (D-250): Setting range from 160 to 320 bar (2300 to 4650 psi), standard setting 250 bar (3600 psi).

**Pilot operated type P:**

- (P-120): Setting range from 60 to 250 bar (870 to 3600 psi), standard setting 120 bar (1750 psi).

**3 Inlet valve options**

- : Blanking plug (omit in description)
- F: Inlet anticavitation valve
- L: Hydraulic pilot unloader valve
- EL: Solenoid operated unloader valve:**
- ELN: Without emergency
- ELP: Push-button emergency
- ELV: Screw type emergency
- ELT: Push and twist type with detent emergency
- Coils for EL:**
- 12VDC: Coil type KETA, ISO 4400 12 V DC
- 24VDC: Coil type KETA, ISO 4400 24 V DC

## 4 Working section

P: Parallel circuit with port valves arrangement

## 5 Spools

A: Double acting, 3 positions, with A and B closed in neutral position.

Af: Same as A, more sensitive.

B: Single acting on A, 3 positions, B plugged.

C: Single acting on B, 3 positions, A plugged.

D: Double acting, 3 positions, with A and B open to tank in neutral position.

E: Double acting, 3 positions, with B open to tank in neutral position.

F: Double acting, 3 positions, with A open to tank in neutral position.

## 6 Spool positioners

1: With spring return in neutral position.

2: With detent in position 1 and spring return in neutral position.

3: With detent in position 2 and spring return in neutral position.

4: 2 positions, position 2 and spring return in neutral position.

5: 2 positions, position 1 and spring return in neutral position.

6: 2 positions, position 1 and spring return in position 2.

7: 2 positions, position 2 and spring return in position 1.

8: Detent in position neutral, 1 and 2.

9: 2 positions, detent in positions 1 and neutral.

10: 2 positions, detent in positions 2 and neutral.

11: 2 positions, detent in positions 1 and 2.

## 7 Complete controls

1H: Double side proportional hydraulic control with spring return to neutral

## 8 Auxiliary valves

o: Valve blanking plug

### Antishock valve

YD-63: Setting range from 63 to 125 bar (900 to 1800 psi), standard setting 63 bar (900 psi).

YD-100: Setting range from 100 to 250 bar (1450 to 3600 psi), standard setting 100 bar (1450 psi).

YD-200: Setting range from 200 to 315 bar (2900 to 4600 psi), standard setting 200 bar (2900 psi).

### Antishock and anticavitation valve

ZD-63: Setting range from 63 to 125 bar (900 to 1800 psi), standard setting 63 bar (900 psi).

ZD-100: Setting range from 100 to 250 bar (1450 to 3600 psi), standard setting 100 bar (1450 psi).

ZD-200: Setting range from 200 to 315 bar (2900 to 4600 psi), standard setting 200 bar (2900 psi).

### Antishock pilot operated valve

YP: Setting range from 63 to 300 bar (900 to 4350 psi), standard setting 175 bar (2550 psi).

### Antishock and anticavitation pilot operated valve

ZP: Setting range from 63 to 300 bar (900 to 4350 psi), standard setting 175 bar (2550 psi).

## 9 Manual control options

- : Without lever box, with dust-proof plate

KZ1: Standard lever box

VI: CD flexible cable connection

## 10 Outlet sections

T1: With side outlet.

T2: With upper outlet.

TC1: With closed center.

TC2: With upper outlet and side carry over.

## 11 Threading specifications

Specify thread type, please, refer to page 2 to see codes for it.